

**Z.E. Eremenko<sup>1</sup>, V.A. Pashynska<sup>1,2</sup>, K.S. Kuznetsova<sup>1</sup>,  
O.I. Shubnyi<sup>1</sup>, N.I. Sklyar<sup>3</sup>, A.V. Martynov<sup>3</sup>**

<sup>1</sup>O.Ya. Usikov Institute for Radiophysics and Electronics of NASU

12, Acad. Proskury St., Kharkiv, 61085, Ukraine

<sup>2</sup>B. Verkin Institute for Low Temperature Physics and Engineering of NASU

47, Nauky Ave., Kharkiv, 61103, Ukraine

<sup>3</sup>Mechanik Institute of Microbiology and Immunology National Academy  
of Medical Sciences of Ukraine

14–16, Pushkins'ka St., Kharkiv, 61057, Ukraine

E-mail: zoya.erehenko@gmail.com

## Microwave dielectrometer application to antibiotic concentration control in water solution

**Subject and Purpose.** This study focuses on the original waveguide-differential dielectrometer designed for complex permittivity measurements of high-loss liquids in the microwave range towards the determination of pharmaceutical ingredient concentrations in water solutions at room temperature. The suitability of the device and effectiveness of the dielectrometry method are tested on such pharmaceutical ingredients as lincomycin and levofloxacin over a wide range of concentrations.

**Methods and Methodology.** The main idea of the method consists in that the complex propagation coefficients of the  $HE_{11}$  wave are obtained from the amplitude and phase shift differences acquired by the wave after it has passed through the two measuring cells of the waveguide-differential dielectrometer.

**Results.** We have shown that the proposed dielectrometry method allows a real-time determination of pharmaceutical ingredient concentrations in water solution by measuring the wave attenuation and phase shift differences. We have found that unless concentrations of pharmaceutical ingredients are low, few free water molecules in water solution are bound to the pharmaceutical ingredients. The number of free water molecules in solution decreases as the concentration of pharmaceutical ingredients rises.

**Conclusion.** The current study confirms that the dielectrometry method and the device developed provide effective determination of pharmaceutical ingredient concentrations in water solutions. Fig. 9. Ref.: 18 items.

**Key words:** complex permittivity, high-loss liquids, waveguide-differential dielectrometer, dielectrometry method, complex wave propagation coefficient.

Development of robust physical methods for the detection of biologically active substances such as antibiotics or other medications in water solutions is one of urgent areas of the research [1, 2]. Its importance for ecological monitoring of water environment and foodstuff control is reasoned by the wide and sometimes uncontrolled usage of antibiotics and other drugs in the agricultural industry involving growing crops, raising fish and animals [3–5], which is still more dramatized by a distinct lack of the appropriate control of pharmaceutical and food industry wastewater composition.

Various precise physical methods were developed to detect antibiotics and other organic pol-

lutants in wastewater treatment processes, namely, high-performance liquid chromatography (HPLC), tandem mass spectroscopy (MS/MS), ultra-high performance liquid chromatography-tandem mass spectroscopy (UPLC-MS/MS) [2, 6, 7]. All these techniques are highly sensitive but depend on very costly equipment and consumables. Moreover, the measuring devices are mainly not portable. So, analysis at the site of sampling is beyond the power of analysts and can be made in laboratory conditions only. It takes a long period of time and requires highly skilled operators [2].

In comparison with the control methods mentioned above, modern radiophysical techniques of

organic compound detection in solutions, particularly dielectrometry, is a promising area of the research and is progressing rapidly. Compared with the traditional control technologies, the dielectrometry method has the advantages of instantaneousness, non-invasiveness, rejection of consumables, low energy consumption, safety, versatility, etc., which gives a significant socio-economic effect. A series of studies [8, 9] are devoted to accurate measurements of microwave dielectric properties of biologically active compound solutions.

The microwave dielectrometry method consists in measuring electromagnetic wave parameters during the wave propagation through a test liquid placed in the dielectrometer measuring cell [10–14]. The determined electromagnetic wave parameters allow the complex permittivity (CP) of the studied liquid to be calculated using the characteristic equation obtained from Maxwell's equations for a particular microwave waveguide or resonator structure.

We pursue our long-term research into microwave dielectrometric parameters of high-loss liquids including water solutions of organic compounds (see, e.g., our previous papers [15–17]) and set ourselves a task to develop a radiophysical non-invasive express method and translate it into a portable device intended for the dynamic control of the organic pollutant level in water samples and based on precision CP measurements of water solutions of organic substances of different classes.

In the current study, a unique microwave dielectrometry device that was designed, developed and equipped with appropriate software in O.Ya. Usykov Institute of Radiophysics and Electronics of the National Academy of Sciences of Ukraine is examined. The subject of this study is the effectiveness of the device in determining concentrations of such antibiotics as levofloxacin and lincomycin in water solutions.

**The dielectrometric method.** The proposed research methodology basically reduces to the measurements of the attenuation difference and the phase shift difference between the two cells in the differential measuring cavity of the dielectrometer after the electromagnetic wave has passed through them. One cell accommodates the reference liquid (distilled water in our case), the other contains the test liquid (water solution of a biologically active compound under study). Of use is the dependence

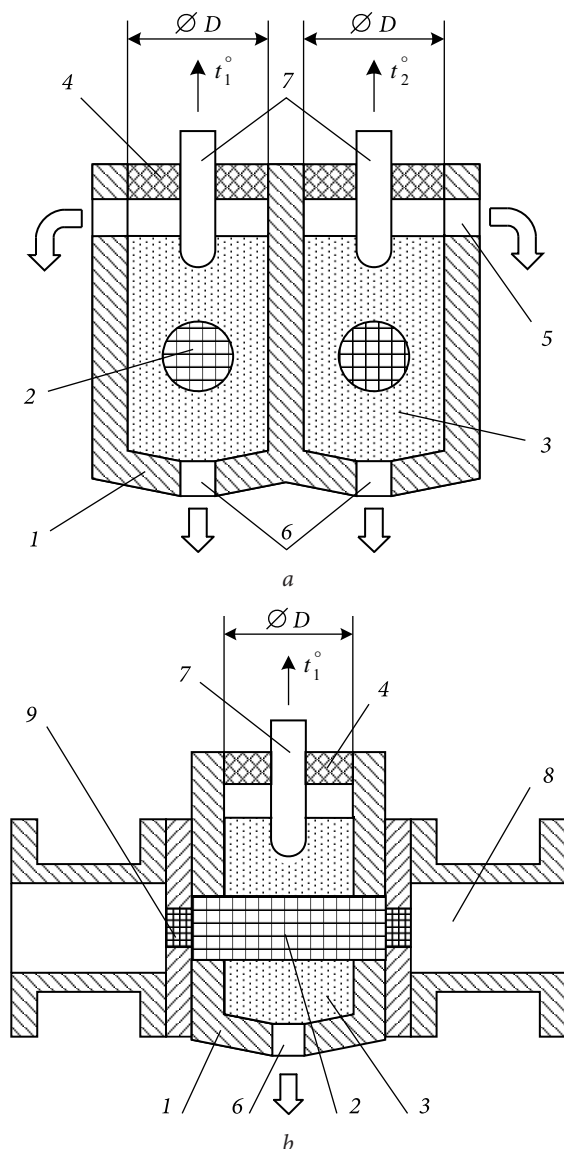

**Fig. 1.** Cross (a) and longitudinal (b) sections of the dielectrometer cavity of two cells: 1 – differential cavity body, 2 – quartz rods, 3 – liquids, 4 – covers, 5 – liquid outlets, 6 – drain holes, 7 – temperature sensors, 8 – rectangular waveguides, and 9 – Teflon gasket

of the complex wave propagation coefficient on the complex permittivity of the liquid in the measuring cell. The complex permittivity is computed based on the characteristic equation and using the measured data on the wave attenuation difference and the wave phase shift difference between the two measuring cells [17].

*Structure of the measuring cavity of the waveguide-differential dielectrometer.* The measuring cavity of our dielectrometer is a differential cavity consisting of two identical cells made of copper (Fig. 1) [17]. One cell is for the reference liq-

uid. The other is for the test liquid. In the middle of each cell, there is a quartz rod of radius  $a = 0.25$  cm and permittivity  $\varepsilon = 3.8 + i 0.0001$  oriented normal to the cell walls. The cell diameter  $b$  equals the cell length  $l = 2$  cm. The test liquid with  $\varepsilon_2 = \varepsilon'_2 + i\varepsilon''_2$ ,  $\varepsilon''_2/\varepsilon'_2 \approx 1$ ,  $\mu_1 = \mu_2 = 1$  fills the interior ( $b - a$ ) in between the cell walls and the quartz rod. We work with the  $HE_{11}$  wave excited in each quartz rod by the rectangular waveguide with the  $H_{11}$  fundamental wave. The phase and attenuation coefficients of the wave passing through the cell correspond to the real  $h'$  and imaginary  $h''$  parts of the complex wave propagation coefficient  $h$ .

The electromagnetic problem for the structure in Fig. 1 was solved [11, 12] by the separation of variables in cylindrical coordinates  $(r, \varphi, z)$ . The field along the rod radius  $r$  is represented by a combination of the Bessel  $J_n(\cdot)$  and Neumann  $N_n(\cdot)$  functions of order  $n$  (the azimuthal oscillation index) in a cylindrical coordinate system. The time dependence  $\exp(-i\omega t)$  is taken.

The complex amplitudes of the electric and magnetic Hertz vectors in the dielectric rod and in the absorbing layer are, respectively,

$$\begin{aligned} U_1^e &= A^e J_n(k_1 r) \sin(n\varphi) \exp(ihz), \\ U_1^m &= A^m J_n(k_1 r) \cos(n\varphi) \exp(ihz), \\ U_2^e &= [B^e J_n(k_2 r) + C^e N_n(k_2 r)] \cos(n\varphi) \exp(ihz), \\ U_2^m &= [B^m J_n(k_2 r) + C^m N_n(k_2 r)] \sin(n\varphi) \exp(ihz). \end{aligned} \quad (1)$$

Here  $A^e$ ,  $A^m$ ,  $B^e$ ,  $B^m$ ,  $C^e$ , and  $C^m$  are the unknown coefficients. Satisfying the boundary conditions on the measurement cell surface yields the characteristic equation for complex propagation coefficient  $h$  as follows

$$(\varepsilon_2 f_n^e - \varepsilon_1 F_n)(\mu_2 f_n^m - \mu_1 F_n) = \frac{n^2 h^2 (k_1^2 - k_2^2)^2}{k_0^2 k_1^4 k_2^4 a^4}, \quad (2)$$

where

$$\begin{aligned} f_n^e &= \frac{N'_n(k_2 a) J_n(k_2 b) - J'_n(k_2 a) N_n(k_2 b)}{k_2 a [N_n(k_2 a) J_n(k_2 b) - J_n(k_2 a) N_n(k_2 b)]}, \\ f_n^m &= \frac{J'_n(k_2 a) N'_n(k_2 b) - N'_n(k_2 a) J'_n(k_2 b)}{k_2 a [J_n(k_2 a) N'_n(k_2 b) - N_n(k_2 a) J'_n(k_2 b)]}, \\ F_n &= \frac{J'_n(k_1 a)}{k_1 a \cdot J_n(k_1 a)}. \end{aligned}$$

The primes stand for the derivatives with respect to the Bessel function arguments,  $k_i$  is the transverse wave number in the rod ( $i = 1$ ) and in the surrounding liquid ( $i = 2$ ). The electromagnetic energy loss in the metal walls of the measuring cells is negligible compared to the dielectric loss in the liquid. The complex roots of implicit characteristic Eq. (2) were calculated using a special computer program in Borland Builder 6.0 environment in the C++ language.

*Measurement errors.* Measurement error estimations for the reference liquid can be found in [11, 12]. Here we suggest some remarks on the origin of the errors. Our dielectrometer based on the differential method offers differential sensibility of the order  $\delta(\Delta\varphi) \approx \pm 0.025$  deg/cm for the phase shift difference  $\Delta\varphi$  measurements and of the order  $\delta(\Delta A) \approx \pm 0.0005$  dB/cm for the amplitude difference  $\Delta A$  measurements in view of the root-mean-square random measurement errors. These figures were attained through a series of measurements with water as the reference liquid and in stable ambient conditions. Taking them into our characteristic equation in the designed computer program yields the  $h'$ ,  $h''$  and  $\varepsilon'$ ,  $\varepsilon''$  errors reported in Table 1.

As seen, the relative errors caused by the complex permittivity measurements of the test liquid are 0.06% for the CP real part and 0.26% for the CP imaginary part.

The Bessel functions in our CP calculation algorithm are another source of errors as they are fast oscillating functions. Let us consider the inaccuracies arising in the CP calculation process. We take the real and imaginary parts of the water complex permittivity from, e.g., [18] and calculate the real and imaginary parts of the complex propagation coefficient,  $h^*$ . Then using the so obtained  $h^*$  values we can solve the inverse problem, i.e. calculate  $\varepsilon^*$  once more and find the difference. Table 2 reports the results.

The relative errors of the real (Eq. (3)) and imaginary (Eq. (4)) parts of the test liquid CP are found to be 0.15% and 0.52%, respectively.

*Calculation procedure of the test liquid complex permittivity.* In order to determine the CP of the test liquid in the course of the relative measurements, one needs to know the complex permittivity of the reference liquid to a high accuracy. When it comes to pharmaceutical ingredients, distilled

water is the reference liquid. The CP of the water comes from the Debye relation. The main idea of the CP determination is to employ the differential method and recognize the amplitude difference  $\Delta A$  and the phase shift difference  $\Delta\varphi$  after the  $HE_{11}$  wave has passed through two liquids with similar CP values. The calculation algorithm of the test liquid CP is shown in Fig. 2.

Table 1. Absolute and relative errors caused by the measurements

$\delta(\varphi)$ , deg/cm	0.025
$\delta(A)$ , dB/cm	0.0005
$(\delta\varphi / \varphi) \times 100\%$	0.027%
$(\delta A / A) \times 100\%$	0.009%
$(\delta h' / h') \times 100\%$	0.004%
$(\delta h'' / h'') \times 100\%$	0.006%
$\left(\frac{\delta \varepsilon'_{mea}}{\varepsilon'_{mea}}\right) \times 100\%$	0.06%
$\left(\frac{\delta \varepsilon''_{mea}}{\varepsilon''_{mea}}\right) \times 100\%$	0.26%

Table 2. Absolute and relative errors caused by the calculations

$\varepsilon'$	20.7685978027281
$\varepsilon''$	31.1264464966551
$h'$ , 1/cm	11.1694761017062
$h''$ , dB/cm	8.74931187358292
$\varepsilon'_{calc}$	20.78849125
$\varepsilon''_{calc}$	31.205587375
$\delta\varepsilon'_{calc} =  \varepsilon' - \varepsilon'_{calc} $	0.019
$\delta\varepsilon''_{calc} =  \varepsilon'' - \varepsilon''_{calc} $	0.079
$\left(\frac{\delta\varepsilon'_{calc}}{\varepsilon'_{calc}}\right) \times 100\%$	0.096%
$\left(\frac{\delta\varepsilon''_{calc}}{\varepsilon''_{calc}}\right) \times 100\%$	0.25%

$$\frac{\Delta\varepsilon'}{\varepsilon'} = \sqrt{\left(\frac{\delta\varepsilon'_{mea}}{\varepsilon'_{mea}}\right)^2 + \left(\frac{\delta\varepsilon'_{calc}}{\varepsilon'_{calc}}\right)^2}; \quad (3)$$

$$\frac{\Delta\varepsilon''}{\varepsilon''} = \sqrt{\left(\frac{\delta\varepsilon''_{mea}}{\varepsilon''_{mea}}\right)^2 + \left(\frac{\delta\varepsilon''_{calc}}{\varepsilon''_{calc}}\right)^2}. \quad (4)$$

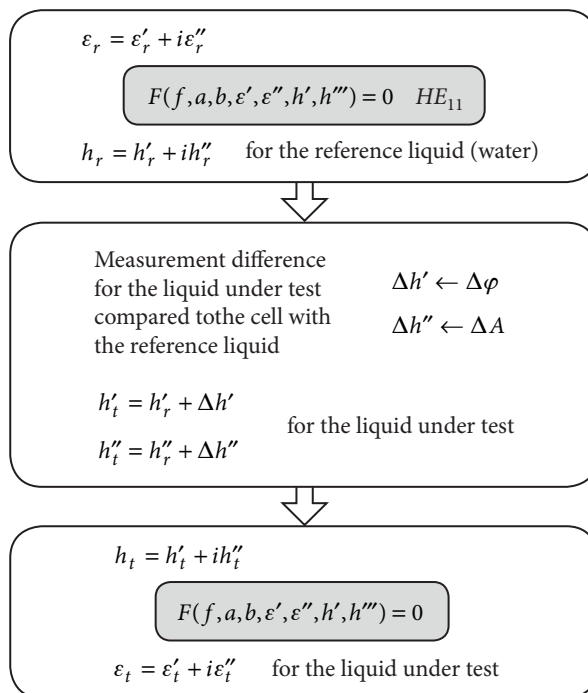

Fig. 2. Algorithm of the CP calculation for the test liquid

The scheme of the CP measurement procedure is as follows:

1) Having solved characteristic Equation (2) and knowing the CP of the reference liquid we find the phase coefficient  $h'_r$  and the attenuation coefficient  $h''_r$  of the reference liquid.

2) The phase shift differences  $\Delta\varphi$  and the amplitude differences  $\Delta A$  are measured related to the two cells. One is filled with the reference liquid. The other contains the liquid under test. The wave phase and attenuation coefficients of the test liquid are calculated as  $h'_t = h'_r + \Delta\varphi$ ,  $\text{rad/cm}^{-1}$  and  $h''_t = h''_r + \Delta A$ ,  $\text{dB/cm}^{-1}$ .

3) Having solved characteristic Equation (2) and knowing  $h'_t$ ,  $h''_t$  one finds the test liquid CP  $\varepsilon_t = \varepsilon'_t + i\varepsilon''_t$ .

*Discussion of the results on antibiotic CP determination in water solution.* The results of pharmaceutical ingredient measurements are given to the following concentrations: 1) 0.18, 0.36, 0.62, 1.25, 2.5, and 5.0 mkg/ml for levofloxacin and 2) 234.37, 468.75, 937.5, 1875, 3750, 7500, and 15000 mkg/ml for lincomycin.

In Figs. 3–5, the phase shift and amplitude differences,  $\Delta\varphi$  and  $\Delta A$ , the wave phase and attenuation coefficients,  $h'$  and  $h''$ , and the CP real and imaginary parts are plotted depending on levofloxacin concentrations in water solutions.

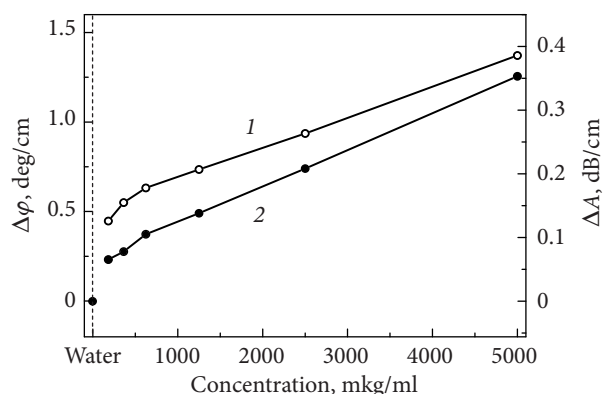

Fig. 3. Phase shift difference  $\Delta\varphi$  (1) and amplitude difference  $\Delta A$  (2) of the  $HE_{11}$  wave versus levofloxacin concentration in water solution at  $t = 17.5 \dots 20$  °C

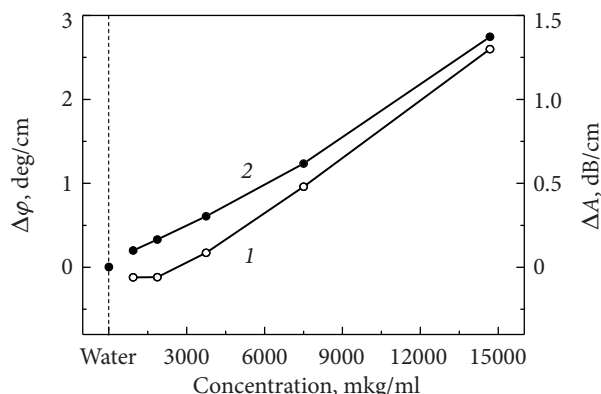

Fig. 6. Phase shift difference  $\Delta\varphi$  (1) and amplitude difference  $\Delta A$  (2) of the  $HE_{11}$  wave versus lincomycin concentration in water solution,  $t = 18 \dots 20$  °C

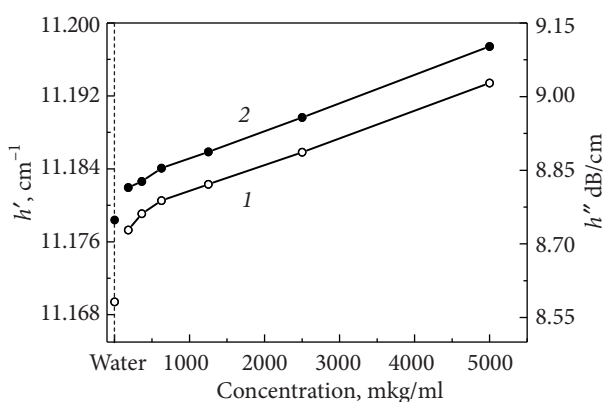

Fig. 4. Wave phase coefficient  $h'$  (1) and attenuation coefficient  $h''$  (2) of the  $HE_{11}$  wave versus levofloxacin concentration in water solution

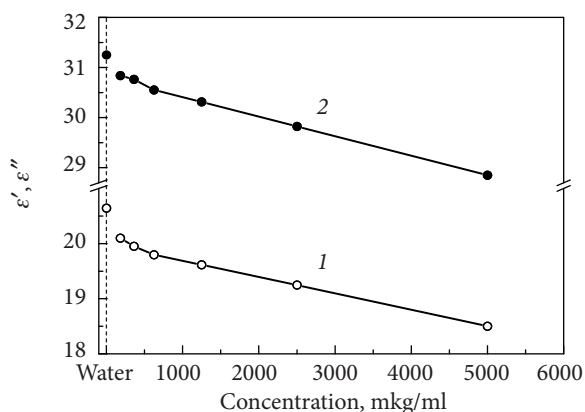

Fig. 5. CP real  $\epsilon'$  and imaginary  $\epsilon''$  parts versus levofloxacin concentration in water solution

The similar dependences for lincomycin are in Figs. 6–8. The reference values (distilled water) are marked out by the dashed vertical line. Graphs are fitted with error bars.

Let us consider the measurement results for antibiotic water solutions. The  $HE_{11}$  wave phase shift

and amplitude versus antibiotic concentration in water solution (Figs. 3 and 6) have almost linear character for all the antibiotic concentrations excluding small-concentration areas. It means that our technique offers a simple and unambiguous dependence of the measured physical parameters on the antibiotic concentration in water solution. Likewise, the real and imaginary parts of the complex propagation coefficient  $h = h' + h''$  demonstrate almost linear dependences, the same as the real and imaginary parts of the complex permittivity  $\epsilon = \epsilon' + \epsilon''$  of the test liquid.

The real and imaginary parts of the test liquid CP become progressively smaller compared to the water CP as the antibiotic concentration in water increases. It means that the free water amount decays as the antibiotic concentration in water solution rises.

The following ideas about the molecular processes going in the water of medication solutions are proposed to explain the above given experimental results. Molecules of hydrophilic substances dissolved in water demonstrate propensity to form hydrated complexes with water molecules. These are readily soluble compounds such as antibiotic salts – gentamicin sulfate, various proteins, etc. With the formation of hydrated complexes, the bounded water molecules are getting structured around the molecules of dissolved hydrophilic biologically active compounds, resulting in the microwave/dielectric constant decrease with the decreasing proportion of free water in the solution. As the dissolved compound concentration increases, the CP correspondingly decreases, as also does the proportion of free water in the solution.

In our experiments, as long as the levofloxacin or lincomycin concentration in water solution is low, not many free water molecules are bounded to antibiotic molecules (Figs. 7, 8). As the levofloxacin or lincomycin concentration in water solution increases, more water molecules get bound to the newly coming antibiotic molecules in hydration processes. A number of free water molecules in water solution decays. The CP real and imaginary parts steadily decrease (Figs. 5 and 8).

It should be noted that the detection time in our experimental measurements of the reference (water) and test liquids was about 30 minutes within a fairly small temperature interval (Fig. 9). The influence of such temperature deviation on CP dependences is supposed rather small. We calculate the differences for the CP real and imaginary parts of water given the temperature of the liquids in the cells changes within 3 °C and the detection time is about 30 minutes. These differences are  $\Delta\varepsilon' = 0.04$  and  $\Delta\varepsilon'' = 0.3$ , and they are much smaller than the measured values for the CP real and imaginary parts of the test liquid.

The liquids in the measuring cells heat up as the electromagnetic wave of a certain microwave power passes through the cells. The microwave signal source used in the circuit has output power of about 100 mW. This power value is justified by the following considerations. The principle of the differential dielectrometer operation involves the output power division into two – reference and measuring – channels. With an E-tee junction, the in-phase power is equally divided between the two channels. The point after which a change in the amplitude shift required to restore the balance disturbed by the replacement of the reference liquid with the test liquid starts with 10 dB attenuation. The reason for the starting attenuation as mentioned is the fact that at this point there is a minimal parasitic change in signal phase when the signal amplitude is changed by the measuring attenuator. In view of the signal absorption during the passage through the liquid in the cell, a high output power of the signal source is needed to ensure a good signal-to-noise ratio.

A number of circuit design and construction solutions, such as a sufficiently high-power signal generator incorporation, have been introduced to the developed dielectrometer structure in order to reduce random measurement errors.

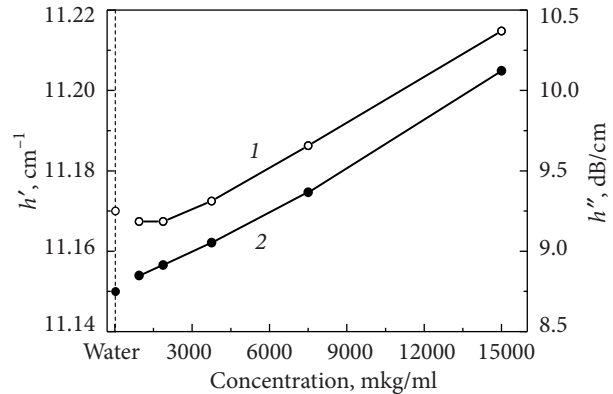

Fig. 7. Wave phase coefficient  $h'$  (1) and attenuation coefficient  $h''$  (2) of the  $HE_{11}$  wave versus lincomycin concentration in water solution

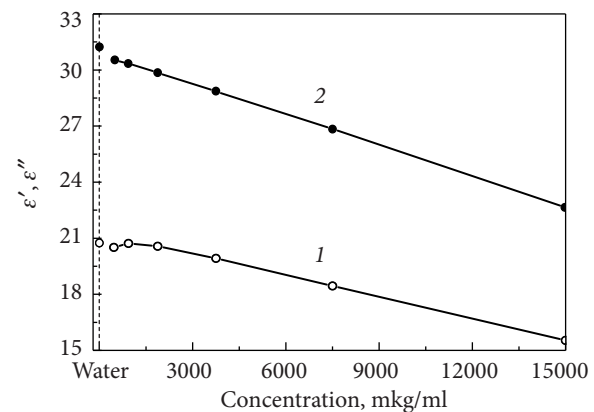

Fig. 8. CP real  $\varepsilon'$  and imaginary  $\varepsilon''$  parts versus lincomycin concentration in water solution

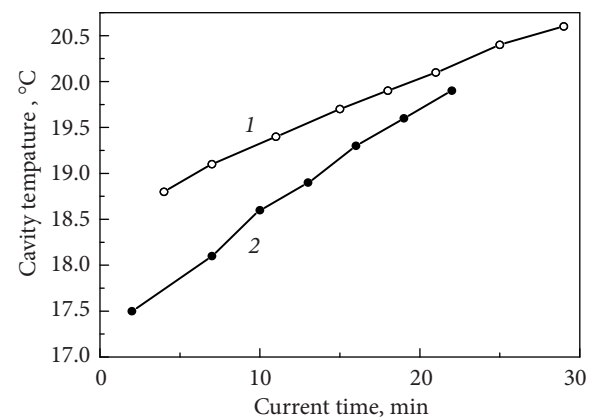

Fig. 9. Test liquid temperature versus the measurement time interval for levofloxacin (1) and lincomycin (2)

The obtained results have shown that the developed microwave dielectrometry method is sensitive to the presence of antibiotics in water solutions and can determine antibiotic concentration changes. Also, the measurement results suggest potential employments of both the method and the

microwave dielectrometry device developed from it and intended for lots of biomedical applications, including blood glucose monitoring, control over the spread of various biological contaminants in the environment and foodstuffs, clinical monitoring of gastrointestinal processes for the diagnosis of stomach and duodenum diseases (pH-value monitoring), characterization of biologically active substances in laboratory diagnostics in human and veterinary medicine.

**Conclusions.** The performed experimental study of water solutions of levofloxacin and lincomycin antibiotics by microwave dielectrometry has shown that the developed dielectrometry method and the constructed from it device can perform a qualitative and quantitative real-time determination of pharmaceutical ingredients in water solutions through the measurements of wave attenuation and phase shift differences. It has been demonstrated that unless the pharmaceutical ingredient

concentration in water solution is low, not many water molecules are bound to medication molecules. As concentrations of pharmaceutical ingredients in water solution increases, a number of free water molecules decreases and, consequently, the CP of the solution does the same. A serious advantage of the microwave dielectrometer developed by our scientific team is its ability to directly measure the concentration of a substance regardless of its structure. We emphasize that the real and imaginary parts of the test liquid CP behave monotonically (almost linearly) where the ingredient concentration is low. It gives us unambiguous dependences of the real and imaginary parts of the test liquid CP.

The measurement results described in the paper indicate that our dielectrometry method can contribute to microwave biosensor technology and give rise to more advanced techniques of pharmaceutical ingredient control in water solutions.

## REFERENCES

1. Munteanu, F.D., Titoiu, A.M., Marty, J.L., Vasilescu, A., 2018. Detection of Antibiotics and Evaluation of Antibacterial Activity with Screen-Printed Electrodes. *J. Sensors*, **18**(3), pp. 1–26. DOI: 10.3390/s18030901.
2. Mason, A., Soprani, M., Korostynska, O., Amirthalingam, A., Cullen, J., Muradov, M., Carmona, E.N., Sberveglieri, G., Sberveglieri, V., Al-Shamma, A., 2018. Real-Time Microwave, Dielectric, and Optical Sensing of Lincomycin and Tylosin Antibiotics in Water: Sensor Fusion for Environmental Safety. *J. Sensors*, **2018**(20), pp. 1–11. DOI: 10.1155/2018/7976105.
3. Gallagher, J., MacDougall, C., 2018. *Antibiotics Simplified*. Chicago: Jones & Bartlett Publ.
4. Stockwell, V.O., Duffy, B., 2012. Use of antibiotics in plant agriculture. *Rev. Sci. Tech.*, **31**(1), pp. 199–210. DOI: 10.20506/rst.31.1.2104.
5. Gelband, H., Miller-Petrie, M., Pant, S., Gandra, S., Levinson, J., Barter, D., White, A., Laxminarayan, R., 2015. The State of the World's Antibiotics. *Center for Disease Dynamics. Economics & Policy* [online]. Available at: [https://cddep.org/publications/state\\_worlds\\_antibiotics\\_2015/](https://cddep.org/publications/state_worlds_antibiotics_2015/)
6. Brown, K.D., Kulis, J., Thomson, B., Chapman, T.H., Mawhinney, D.B., 2006. Occurrence of antibiotics in hospital, residential, and dairy effluent, municipal wastewater, and the Rio Grande in New Mexico. *Sci. Total Environ.*, **366**(2–3), pp. 772–783. DOI: 10.1016/j.scitotenv.2005.10.007.
7. Qiu, P., Guo, X., Wang, N., Kong, X., He, H., 2015. Simultaneous determination of ten antibiotics in pharmaceutical wastewater using ultra-high performance liquid chromatography-tandem mass spectrometry. *Chin. J. Chromatogr.*, **33**(7), pp. 722–29. DOI: 10.3724/sp.j.1123.2015.03039.
8. Wei, Y., Sridhar, S., 1992. Biological application of a technique for broad complex permittivity measurements. *IEEE MTT-S Microwave Symposium Digest* [pdf]. IEEE. Available at: <https://citeseerx.ist.psu.edu/viewdoc/download?doi=10.1.1.718.8710&rep=rep1&type=pdf>
9. Kouzai, M., Nishikata, A., Fukunaga, K., and Miyaoka, Sh., 2007. Complex permittivity measurement at millimeter-wave frequencies during fermentation process of Japanese sake. *J. Phys. D: Appl. Phys.*, **40**(1), pp. 54–60.
10. Eremenko, Z.E., Ganapolskii, E.M., 2003. Hemispherical cavity resonator for measuring of permittivity of strongly absorbing liquid in small volume. *Telecommunications and radio Engineering*, **60**(1–2), pp. 61–74. DOI: 10.1615/TelecomRadEng.v60.i12.70.
11. Eremenko, Z.E., Ganapolskii, E.M., Vasilchenko, V.V., 2005. Exact-calculated resonator method for permittivity measurement of high loss liquids at millimeter wavelength. *Meas. Sci. Technol.*, **16**(8), pp. 1619–1627.
12. Eremenko, Z.E., Ganapolskii, E.M., Vasilchenko, V.V., 2005. Layered ball resonator for permittivity measurement method of high loss liquids at millimeter wavelength. In: *Proc. of 35th European Microwave Conference 2005*. Paris, France, 4–6 Oct. 2005, Vol. 2, pp. 1007–1010.
13. Gatash, S.V., 1999. Very high frequency dielectrometer for the study of dynamical properties in disperse water systems. In: V.M. Yakovenko, ed. 1999. *Radiofizika i elektronika*. Kharkov: IRE NAS of Ukraine Publ. **4**(1), pp. 129–132 (in Russian).
14. Lavrinovich, A.A., Filippov, Yu.F., Cherpak, N.T., 2004. Spectral properties of a disk quasi-optical dielectric resonator with an inhomogeneity in the form of a capillary with water. In: V.M. Yakovenko, ed. 2004. *Radiofizika i elektronika*. Kharkov: IRE NAS of Ukraine Publ. **9**(3), pp. 496–502 (in Russian).

15. Eremenko, Z.E., Skresanov, V.N., Shubnyi, A.I., Anikina, N.S., Gerzhikova, V.G., Zhilyakova, T.A., 2011. Complex permittivity measurement of high loss liquids and its application to wine analysis. In: V. Zhurbenko, ed. 2011. *Electromagnetic Waves*. Technical University of Denmark, 2011. Ch. 19. DOI: 10.5772/17748.
16. Eremenko, Z.E., Kuznetsova, K.S., Sklyar, N.I., Martynov, A.V., 2019. Measuring Complex Permittivity of High-Loss Liquids. In: P.K. Choudhury, ed. 2019. *Dielectric Materials and Applications*. Nova Science Publisher, 2019. Ch. 2.
17. Skresanov, V.N., Eremenko, Z.E., Glamazdin, V.V., Shubnyi, A.I., 2011. Improved differential Ka band dielectrometer based on the wave propagation in a quartz cylinder surrounded by high loss liquid under test. *Meas. Sci. Tech.*, **22**(3), pp. 065403(10 p.). DOI: 10.1088/0957-0233/22/6/065403.
18. Ellison, W.J., Lamkaourchi, K., Moreau, M.J., 1996. Water: A dielectric reference. *J. Mol. Liq.*, **68**(2–3), pp. 171–279. DOI: 10.1016/0167-7322(96)00926-9.

Received 01.06.2021

З.Є. Єременко<sup>1</sup>, В.А. Пашинська<sup>1,2</sup>, К.С. Кузнєцова<sup>1</sup>,  
О.І. Шубний<sup>1</sup>, Н.І. Скляр<sup>3</sup>, А.В. Мартинов<sup>3</sup>

<sup>1</sup> Інститут радіофізики та електроніки ім. О.Я. Усикова НАН України

12, вул. Акад. Проскури, Харків, 61085, Україна

<sup>2</sup> Фізико-технічний інститут низьких температур імені Б.І. Веркіна НАН України

47, просп. Науки, Харків, 61103, Україна

<sup>3</sup> Інститут мікробіології та імунології ім. І.І. Мечникова НАМН України

14–16, вул. Пушкінська, Харків, 61057, Україна

#### ЗАСТОСУВАННЯ МІКРОХВИЛЬОВОГО ДІЛЕКТРОМЕТРА ДЛЯ КОНТРОЛЮ КОНЦЕНТРАЦІЇ АНТИБІОТИКІВ У ВОДНОМУ РОЗЧИНІ

**Предмет і мета роботи.** Це дослідження зосереджене на оригінальному хвилевідно-диференціальному діелектрометрі, що призначений для вимірювання комплексної діелектричної проникності рідин із великими втратами у мікрохвильовому діапазоні при застосуванні для визначення концентрацій фармацевтичних інгредієнтів у водних розчинах за кімнатної температури. Для перевірки придатності пристрою та визначення ефективності методу діелектрометрії для контролю концентрації антибіотиків у водному розчині використовуються фармацевтичні інгредієнти, такі як лінкоміцин та левофлоксацин у широкому діапазоні концентрацій.

**Методи та методологія роботи.** Основна ідея методу досліджень заснована на визначенні складних коефіцієнтів поширення хвилі за рахунок визначення різниці фаз та амплітуд хвиль у двох вимірювальних порожнинах хвилевідно-диференціального діелектрометра.

**Результати роботи.** Показано, що запропонований метод діелектрометрії дозволяє у реальному часі визначати концентрацію фармацевтичних інгредієнтів у водному розчині шляхом вимірювання значень загасання хвилі та різниці коефіцієнтів фаз. Виявлено, що у разі низької концентрації антибіотиків у розчині мало вільних молекул води буде зв'язуватися з фармацевтичними інгредієнтами. Збільшення концентрації фармацевтичних інгредієнтів у водному розчині спричинює зменшення кількості вільних молекул води у розчині.

**Висновок.** Це дослідження підтверджує, що розроблений метод та пристрій ефективні для визначення концентрації фармацевтичних інгредієнтів у водних розчинах.

**Ключові слова:** комплексна діелектрична проникність, рідини з високими втратами, хвилевідно-диференціальний діелектрометр, метод діелектрометрії, комплексний коефіцієнт поширення хвилі.